

Attributes Acceptance Sampling – Understanding How it Works

Dan O’Leary CBE, CQE, CRE, CSSBB, CIRM
Ombu Enterprises, LLC

603-209-0600

OmbuEnterprises@msn.com

Copyright © 2008, 2009 by Ombu Enterprises, LLC

Instructor Introduction

- Dan O’Leary
 - Dan has more than 30 years experience in quality, operations, and program management in regulated industries including aviation, defense, medical devices, and clinical labs. He has a Masters Degree in Mathematics; is an ASQ certified Biomedical Auditor, Quality Engineer, Reliability Engineer, and Six Sigma Black Belt; and is certified by APICS in Resource Management.
- Ombu Enterprises, LLC
 - Ombu works with small manufacturing companies, offering training and execution in Operational Excellence. Focusing on the analytic skills and systems approach of operations management, Ombu helps companies achieve efficient, effective process and regulatory compliance.

Sampling Plans

Some Initial Concepts

A Typical Application

- You just received a shipment of 5,000 widgets from a new supplier.
- Is the shipment good enough to put into your inventory?

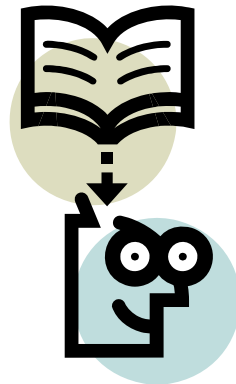

How will
you decide?

You have a few approaches

- Consider three potential solutions
 - Look at all 5,000 widgets (100% inspection)
 - Don't look at any, put the whole shipment into stock (0% inspection)
 - Look at some of them, and if enough of those are good, keep the lot (Acceptance sampling)
- In a sampling plan, we need to know:
 - How many to inspect or test?
 - How to distinguish “good” from “bad”?
 - How many “good” ones are enough?

First we need to distinguish two kinds of information

Attributes

- We classify things using attributes
 - A stop light can be one of three colors: red, yellow, or green
 - The weather can be sunny, cloudy, raining, or snowing
 - A part can be conforming or nonconforming

Variables

- We measure things using variables
 - The temperature of the oven is 350° F
 - The tire pressure is 37 pounds per square inch (psi).
 - The critical dimension for this part number is 3.47 inches.

We can also convert variables into attributes (often using a specification)

- Consider an important dimension with a specification of 3.5 ± 0.1 inches.
 - Piece A, at 3.56 inches is conforming.
 - Piece B, at 3.39 inches is nonconforming.

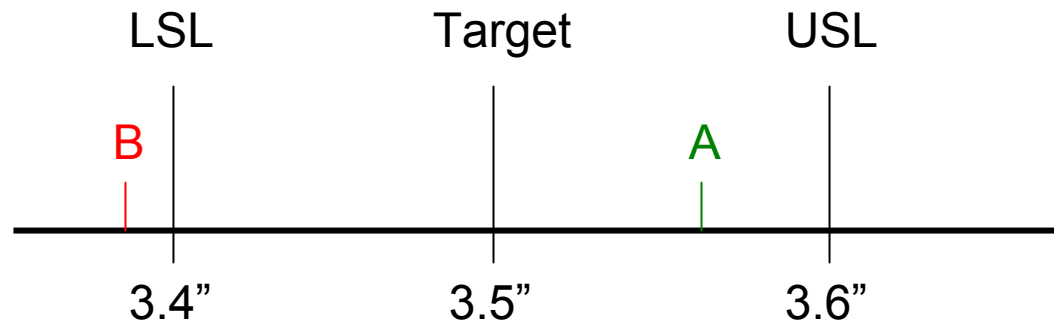

Specification is 3.5 ± 0.1

A note about language

- Avoid “defect” or “defective”
 - They are technical terms in the quality profession, with specific meaning
 - They are also technical terms in product liability, with a different meaning
 - They have colloquial meaning in ordinary language
- I encourage the use of “nonconformances” or “nonconforming”

We will look at two published attribute sampling plans

- ANSI/ASQ Z1.4 is the classic plan, evolved from MIL-STD-105
- The $c=0$ plans are described in *Zero Acceptance Number Sampling Plans* by Squeglia

There are some process steps where acceptance sampling is common . . .

- The most common place for acceptance sampling is incoming material
 - A supplier provides a shipment, and we judge its quality level before we put it into stock.
- Acceptance sampling (with rectifying inspection) can help protect from processes that are not capable
- Destructive testing is also a common application of sampling

. . . but acceptance sampling isn't appropriate in some cases

- Acceptance sampling is **not** process control
- Statistical process control (SPC) is the preferred method to prevent nonconformances.
- Think of SPC as the control method, and acceptance sampling as insurance
- You practice good driving techniques, but you don't cancel your insurance policy

Attribute Sampling Plans

Single Sample Example

We start with an exercise, and then explain how it works

- Your supplier submits a lot of 150 widgets and you subject it to acceptance sampling by attributes.
- The inspection plan is to select 20 widgets at random.
 - If 2 or fewer are nonconforming, then accept the shipment.
 - If 3 or more are nonconforming, then reject the shipment.

In symbols:

$N = 150$

$n = 20$

$c = 2, r = 3$

This is a Z1.4 plan that we will examine in detail.



Here is the basic approach

- Select a single simple random sample of $n = 20$ widgets.
- Classify each widget in the sample as conforming or nonconforming (attribute)
- Count the number of nonconforming widgets
- Make a decision (accept or reject) on the shipment
- Record the result (quality record)

Attribute Sampling Plans

ANSI/ASQ Z1.4

Current status of the standards

- MIL-STD-105
 - The most recently published version is MIL-STD-105E
 - Notice 1 cancelled the standard and refers DoD users to ANSI/ASQC Z1.4-1993
- ANSI/ASQ Z1.4
 - Current version is ANSI/ASQ Z1.4-2003
- FDA Recognition
 - The FDA recognizes ANSI/ASQ Z1.4-2003 as a General consensus standard
 - Extent of Recognition: All applicable single, double, and multiple sampling plans.

Getting started with Z1.4

- To correctly use Z1.4, you need to know 5 things
 - Lot Size
 - Inspection Level
 - Single, Double, or Multiple Sampling
 - Lot acceptance history
 - AQL

The Flow of Information

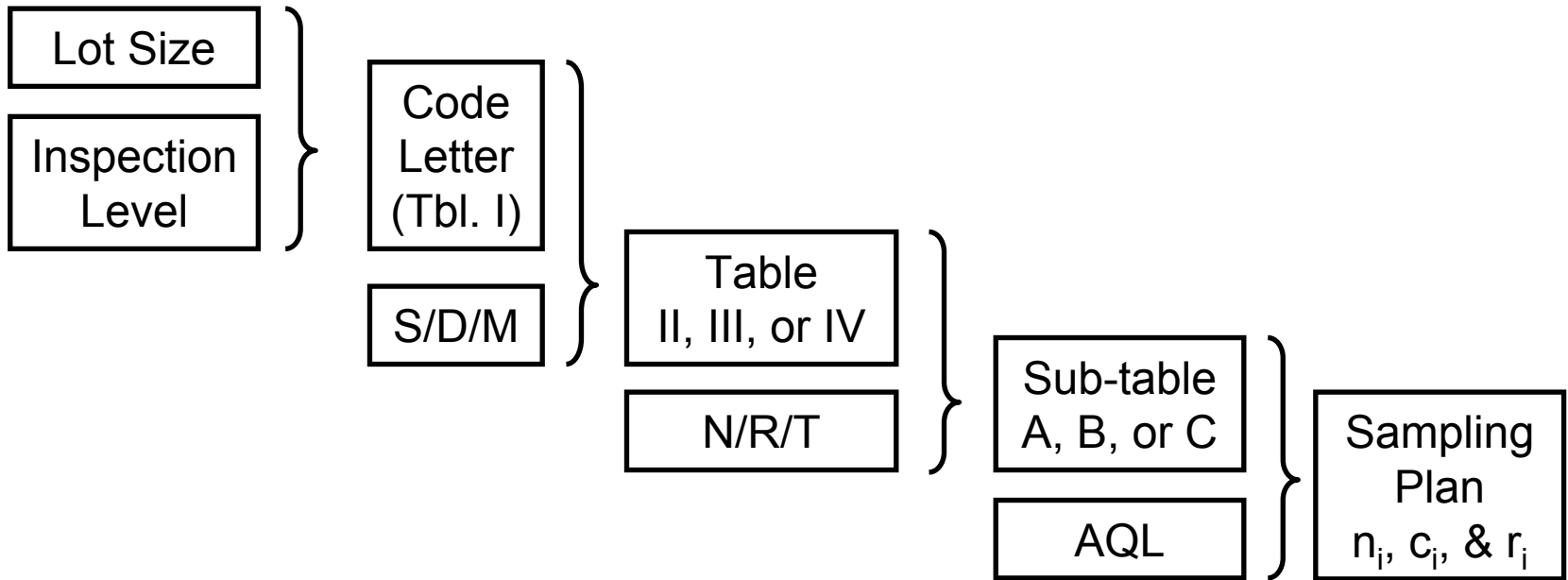

Traditional Information Sources
Purchasing – Lot Size
Quality Engineer – Inspection Level, S/D/M, AQL
Lot History – N/R/T

Lot Size

- The lot size is the number of items received at one time from the supplier.
- For incoming inspection, think of it as the quantity on the pack slip.
- The Purchase Order (or contract) typically sets the lot size.

Inspection Level

- The inspection level determines how the lot size and the sample size are related
 - Z1.4 provides seven different levels: S1, S2, S3, S4, I, II, and III.
 - Use Inspection Level II unless you have a compelling reason to do something else.
- The Quality Engineer sets the Inspection Level.

Code Letter

- The Inspection Level and Lot Size combine to determine the code letter.
 - Use Table I to determine the code letter.

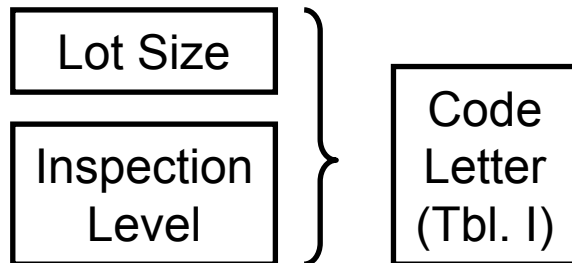

Single, Double, or Multiple Sampling (S/D/M)

- Decide the type of sampling plan (Single, Double, or Multiple)
- This is a balance between average sample number (ASN) and administrative difficulty.
- Generally, moving from single to double to multiple
 - The ASN goes down
 - The administrative difficulty goes up

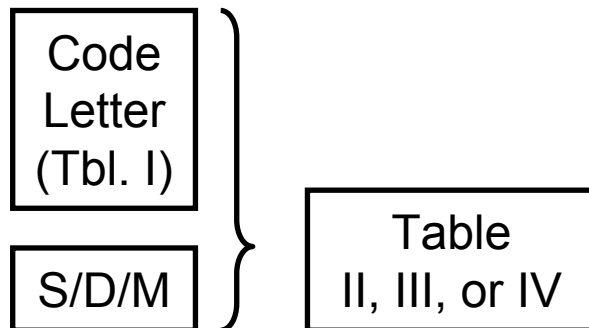

Lot acceptance history

- Z1.4 uses a system of switching rules
- Based on the lot history, we inspect the same (normal), less (reduced), or more (tightened).

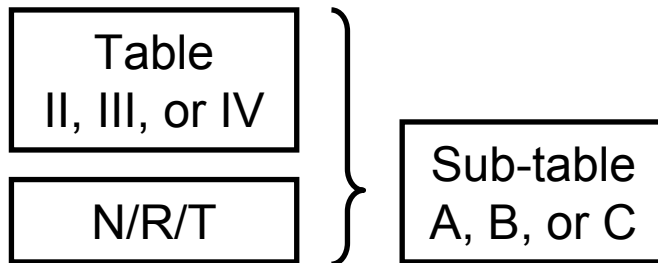

Inspection States

- The system can be in one of four states:
 - Normal
 - Reduced
 - Tightened or
 - Discontinue

AQL

- We will discuss AQL shortly
 - Z1.4 uses the AQL to index the sampling plans.
 - The supplier's process average should be as low as possible, but certainly less than the Z1.4 AQL.
- The Quality Engineer sets the AQL.

Sampling Plan

- The type and history get us to the right table.
- The Code Letter and AQL get us to the sampling plan.
- Note, however, that you may have to use the “sliders” to get the sampling plan.

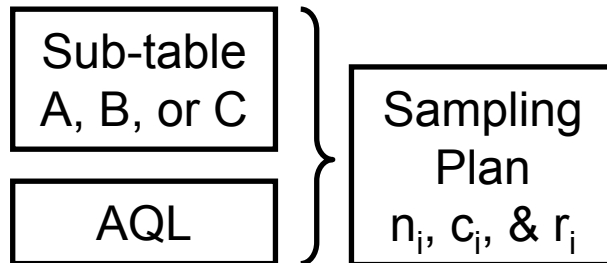

Exercise #1

- Conduct Exercise #1
- Discussion Points
 - If you accept the lot, but had 2 nonconforming items from the sample, what quantity do you record going into stock?
 - Given the conditions above, how many do you pay for?
 - Did you expect to make the same decision (accept or reject the shipment) on each of the five samples?
 - This is a simple random sample. What if the material were in containers, say bags of twenty-five. How would you take the sample?
 - Square root + 1 rule

The Sliders

- Sometimes the Code Letter, Level, and AQL don't have a plan.
 - Z1.4 will send you a different plan using the “sliders” These are arrows pointing up or down.
 - Use the new plan (with the new code letter, sample size, accept number, and reject number).
- Modify Exercise #1 by changing the AQL from 4.0% to 1.0%.
 - What is the sampling plan after the change?
 - *Answer: $n = 13, c = 0, r = 1$*

Changing the lot size

- Your supplier has been shipping 150 units in the lot, based on the Purchase Order, for a long time.
- Your supplier calls your buyer and says, “We were near the end of a raw material run, and made 160 widgets, instead of 150. Can I ship all 160 this time?”
- The buyer says, “Sure no problem. I’ll send a PO amendment.”
- What is the sampling plan?
 - Answer: $n = 32$, $c = 3$, $r = 4$

Sampling Schemes

- Z1.4 tracks the history of lot acceptance and the sampling plans as a result.
 - Consistently good history can reduce the sample size
 - Consistently poor history can shift the OC Curve
- The figure is a simplified version of the switching rules

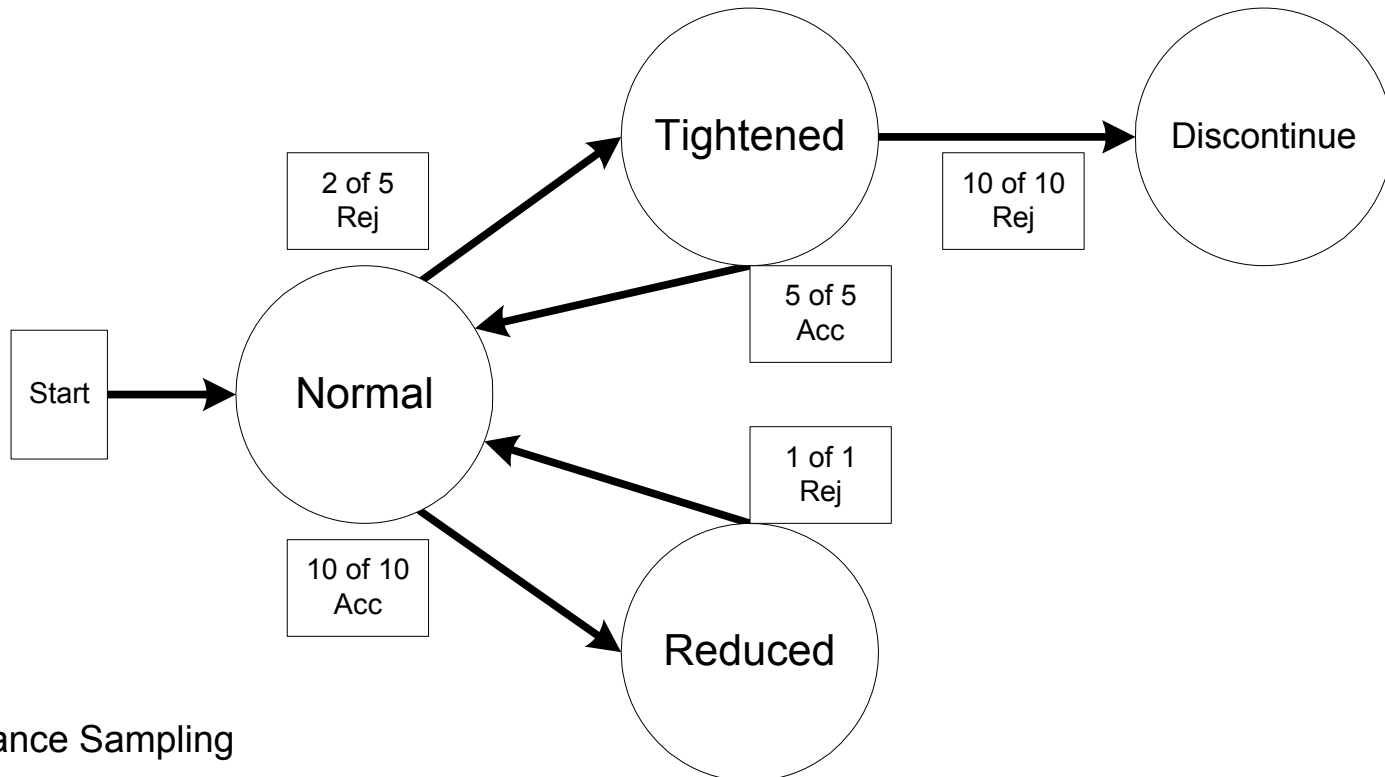

Sampling

Some Common Concepts

Sampling With/Without Replacement

- When we took the widget sample, we didn't put them back into the lot during sampling, *i.e.*, we didn't replace them.
- This changes the probabilities of the rest of the lot.
 - If the lot is large, it doesn't make too much difference.
 - For small lots we need the hypergeometric distribution for the calculation.
- In acceptance sampling we sample without replacement!

Simple v. Stratified Sampling

- Assume the lot has N items
 - In a simple random sample each piece in the lot has equal probability of being in the sample.
 - In a stratified sample, the lot is divided into H groups, called strata. Each item in the lot is in one and only one stratum.
- You receive a shipment of 5,000 AAA batteries in 50 boxes of 100 each.
 - First you take a sample of the boxes, then you take a sample of the batteries in the sampled boxes
 - This is a stratified sample: $N=5,000$ & $H=50$.

Our Conventions

- Unless we say otherwise we make the following conventions
 - Sampling is performed without replacement
 - Sampling is a simple random sample

The Binomial Distribution

First we need the concept of a Bernoulli trail

- Bernoulli trials are a sequence of n independent trials, where each trial has only two possible outcomes.
- Example – Flip a coin fifty times
 - This is a sequence of trials
 - $n = 50$
 - The trials are independent, because the coin doesn't “remember” the previous trial
 - The only outcome of each trial is a head or a tail

With a little math, we define the binomial distribution

- The Bernoulli trial has two possible outcomes.
 - One outcome is “success” with probability p .
 - The other “failure” with probability $q = 1 - p$.
- The binomial distribution is the probability of x successes in n trials

$$\Pr(x) = \binom{n}{x} p^x (1-p)^{n-x}, \quad x = 0, 1, \dots, n$$

Here is an example worked in Excel

$$n = 20, p = 0.1$$

What is the probability of exactly 0 successes, 1 success, etc.

s	Pr(s)
0	0.1216
1	0.2702
2	0.2852
3	0.1901
4	0.0898
5	0.0319
6	0.0089
7	0.0020
8	0.0004
9	0.0001
10	0.0000
11	0.0000
12	0.0000
...	...
20	0.0000

BINOMDIST(number_s, trials, probability_s, cumulative)

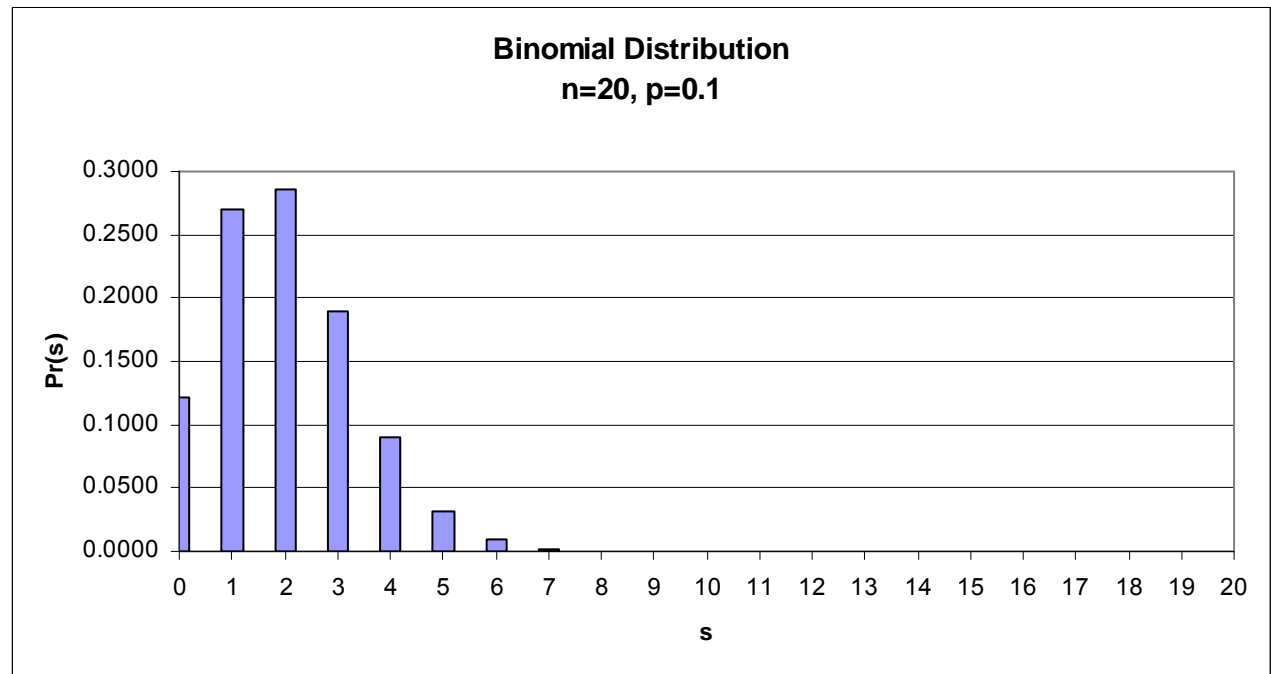

Attribute Sampling Plans

Single Sample Plans

Attribute Sampling Plans

- Single sample plans – Take one sample selected at random and make an accept/reject decision based on the sample
- Double sample plans – Take one sample and make a decision to accept, reject, or take a second sample. If there is second sample, use both to make an accept/reject decision.
- Multiple sample plans – Similar to double sampling, but more than two samples are involved.

The AQL concept

- The AQL is the poorest level of quality (percent nonconforming) that the process can tolerate.
- The input to this process (where I inspect) is defined as:
 - The supplier produces product in lots
 - The supplier uses essentially the same production process for each lot
 - The supplier's production process should run as well as possible, *i.e.*, the process average nonconforming should be as low as possible
- This “poorest level” is the *acceptable quality level* or AQL.

The intentions of the AQL

- The AQL provides a criterion against which to judge lots.
- It does not
 - Provide a process or product specification
 - Allow the supplier to knowingly submit nonconforming product
 - Provide a license to stop continuous improvement activities

A simplified view of the relationship between process control and acceptance sampling

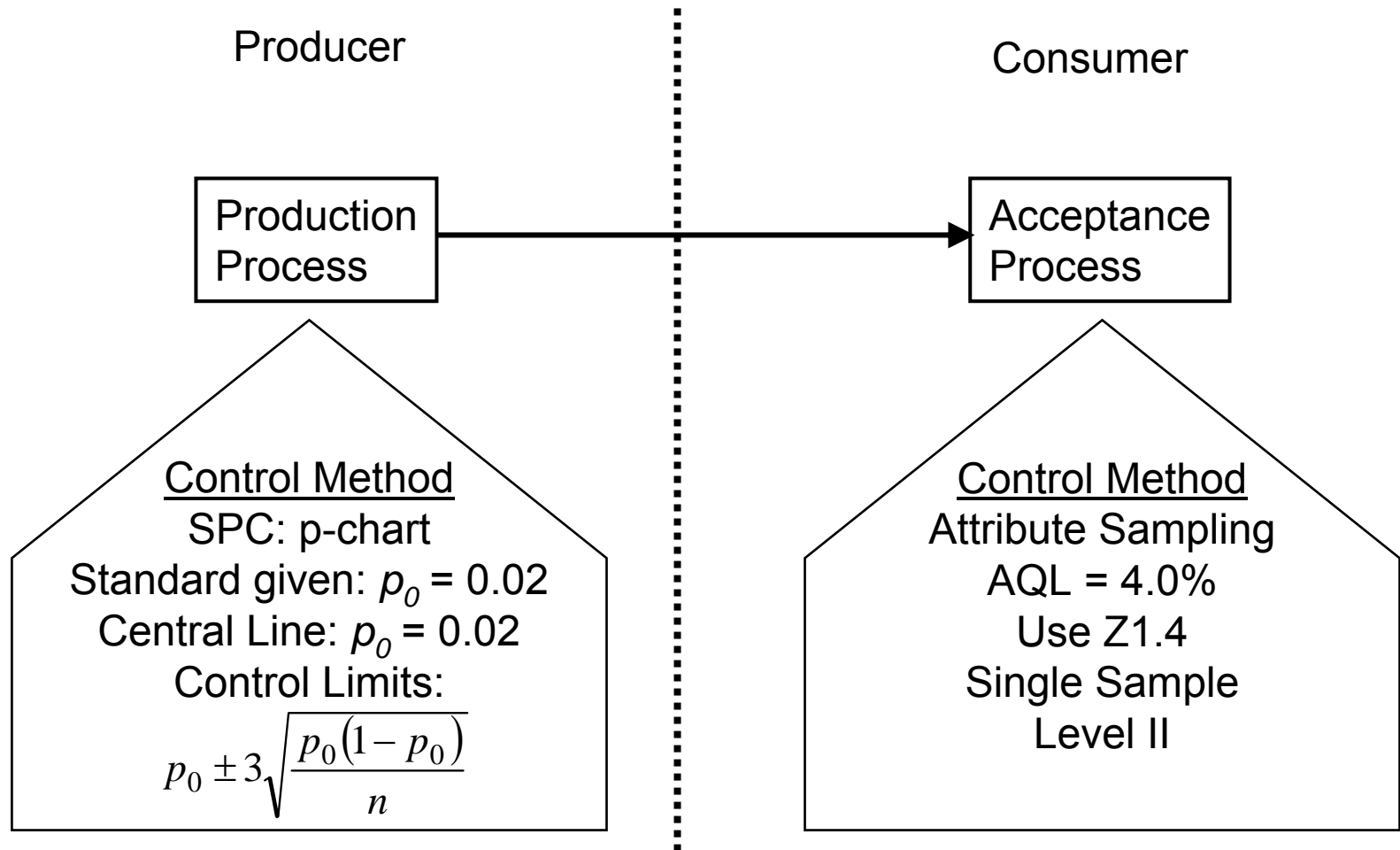

What does AQL mean?

- If the supplier's process average nonconforming is below the AQL, the consumer will **accept** all the shipped lots.
- If the supplier's process average nonconforming is above the AQL, the consumer will **reject** all the shipped lots.

Illustrates an AQL of 4.0%

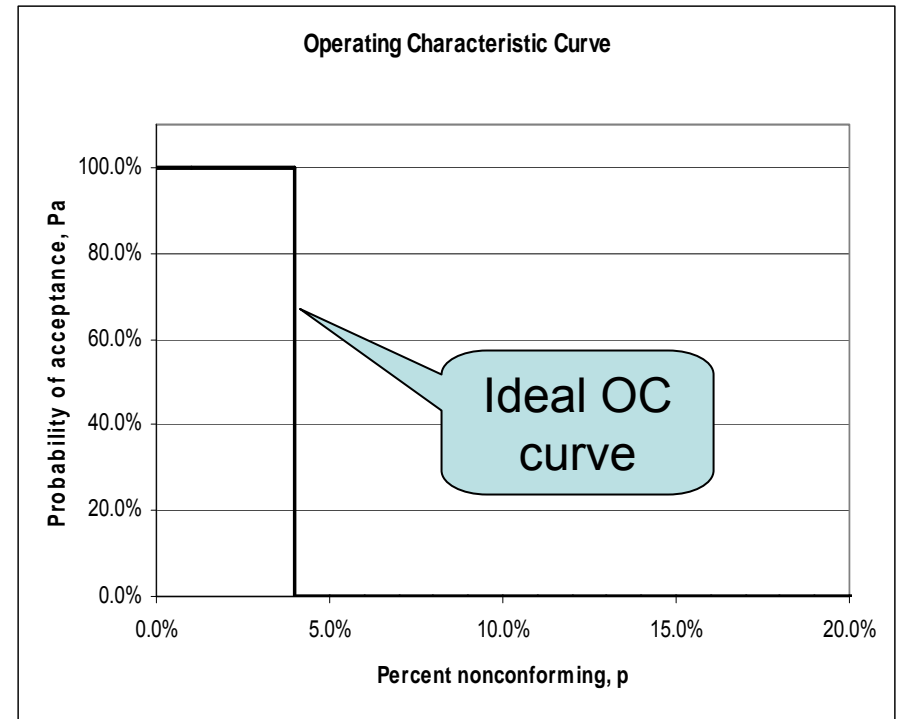

Sampling doesn't realize the ideal OC curve

Increasing n (with c proportional) approaches the ideal OC curve.

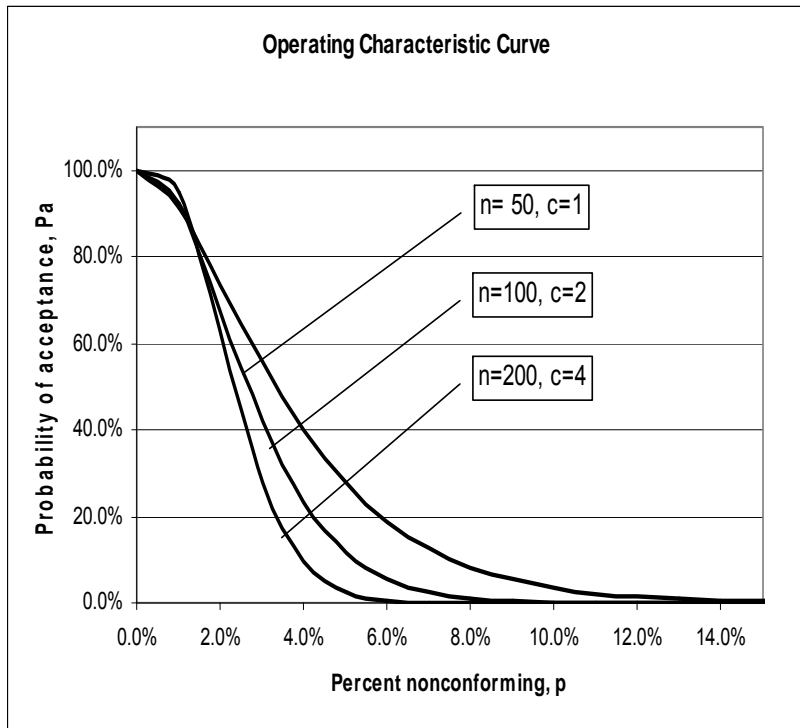

Increasing c (with n constant) approaches the ideal OC curve.

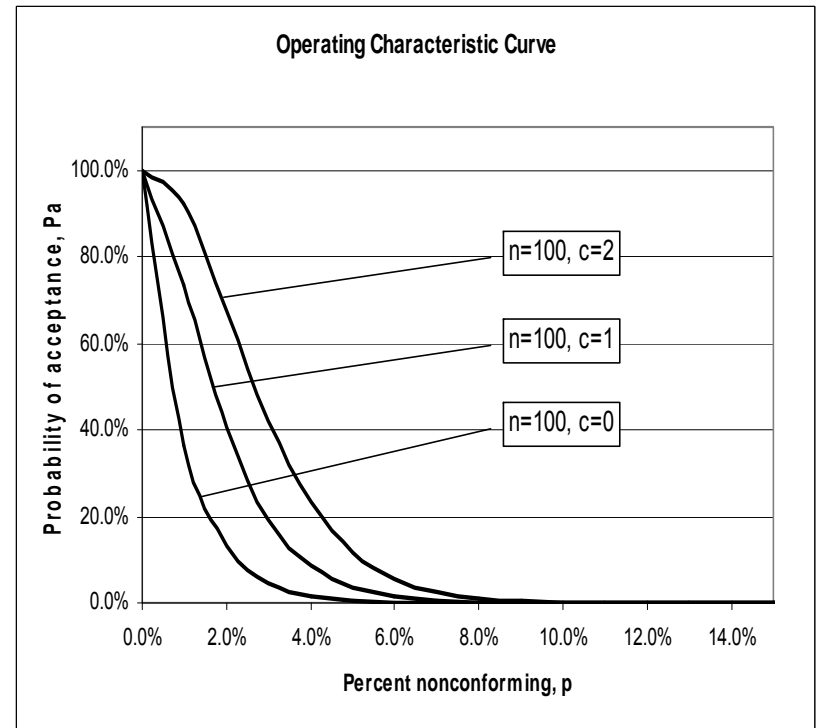

Because we don't have an ideal OC curve, we must consider four possible outcomes

Producer's Risk – The probability of rejecting a "good" lot.

Consumer's Risk – The probability of accepting a "bad" lot.

		Consumer's Decision	
		Accept	Reject
Producer's Activity	Lot conforms	OK	Producer's Risk
	Lot doesn't conform	Consumer's Risk	OK

We can identify some specific points of interest on the OC Curve

The Producer's Risk has a value of α .
The point $(p_1, 1-\alpha)$ shows the probability of accepting a lot with quality p_1 .

The Consumer's Risk has a value of β .
The point (p_2, β) shows the probability of accepting a lot with quality p_2 .

The point $(p_3, 0.5)$ shows the probability of acceptance is 0.5.

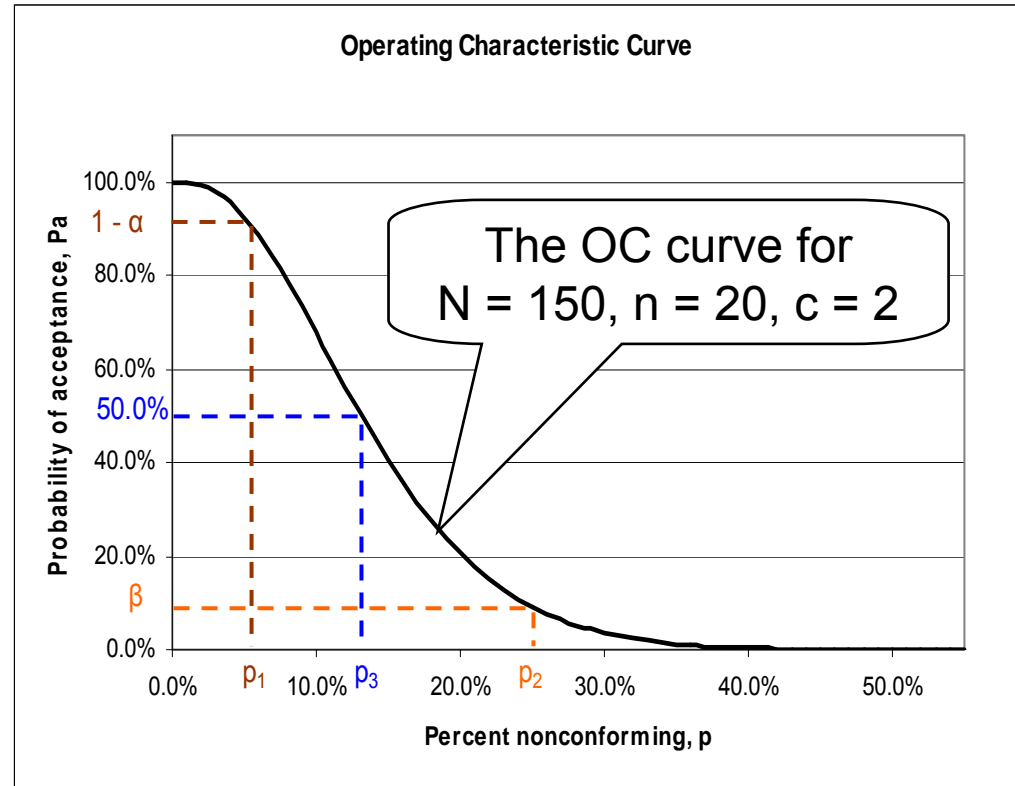

Take caution with some conventions

- Some conventions for these points include $\alpha = 5\%$ and $\beta = 5\%$
 - The point $(p1, 1-\alpha) = (\text{AQL}, 95\%)$
 - The point $(p2, \beta) = (\text{RQL}, 5\%)$
- We also see $\alpha = 5\%$ and $\beta = 10\%$
 - The point $(p1, 1-\alpha) = (\text{AQL}, 95\%)$
 - The point $(p2, \beta) = (\text{RQL}, 10\%)$
- Z1.4 doesn't adopt these conventions

Here is the previous OC Curve with the points named

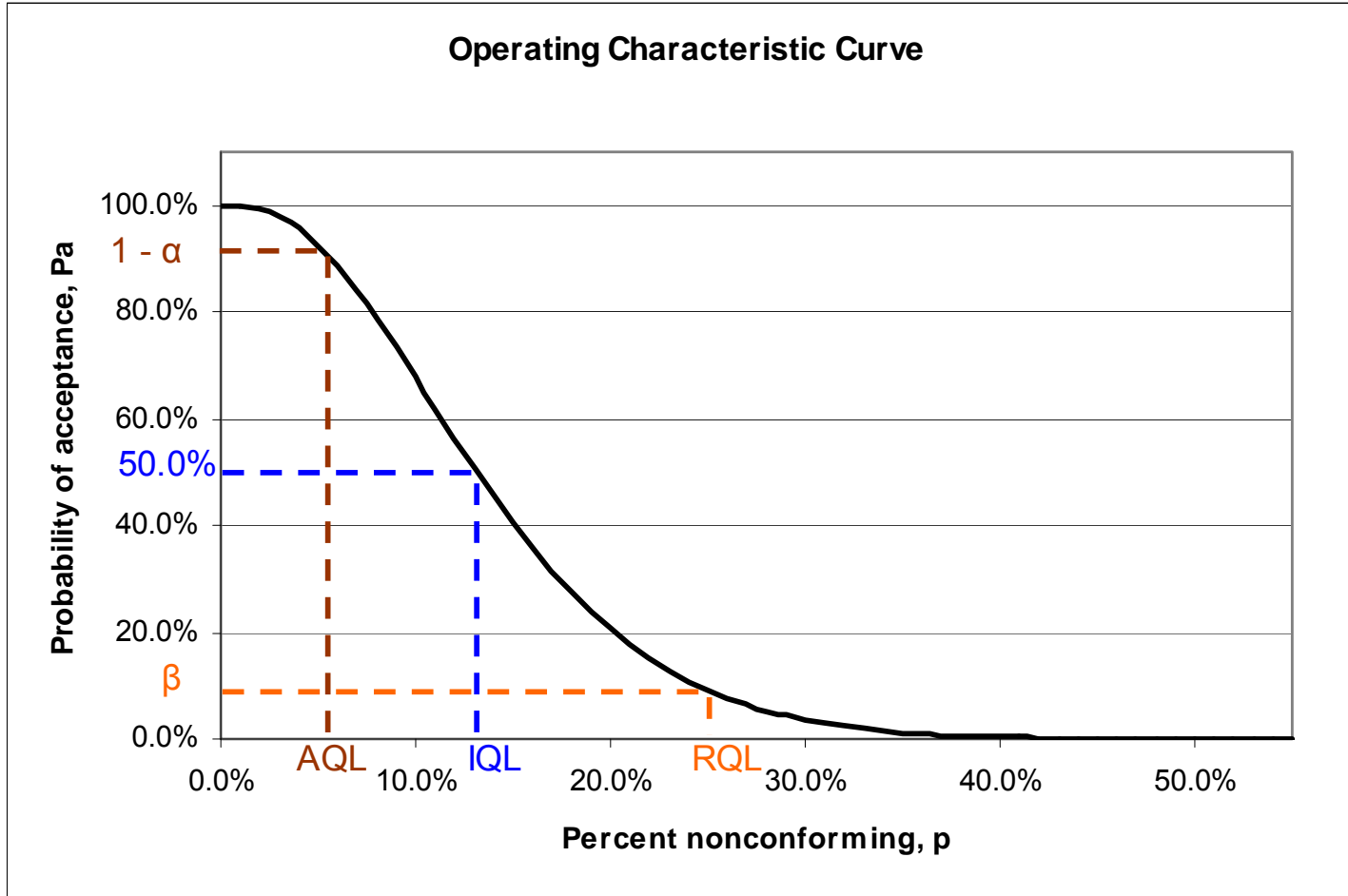

Characterizing attribute sampling plans

- We typically use four graphs to tell us about a sampling plan.
 - The Operating Characteristic (OC) curve
 - The probability of acceptance for a given quality level.
 - The Average Sample Number (ASN) curve
 - The expected number of items we will sample (most applicable to double, multiple, and sequential samples)
 - The Average Outgoing Quality (AOQ) curve
 - The expected fraction nonconforming after rectifying inspection for a given quality level.
 - The Average Total Inspected (ATI) curve
 - The expected number of units inspected after rectifying inspection for a given quality level.

Rectifying Inspection

- For each lot submitted, we make an accept/reject decision.
 - The accepted lots go to stock
- What do we do with the rejected lots?
 - One solution is to subject them to 100% inspection and replace any nonconforming units with conforming ones.
 - For example, a producer with poor process capability may use this approach.
- Two questions come to mind
 - How many are inspected on average?
 - What happens to outgoing quality after inspection?

Average Outgoing Quality (AOQ)

Screen the sample
Screen the rejected lots

Screening means to replace all nonconforming units with conforming units.

$$AOQ = \frac{P_a p(N - n)}{N}$$

The Average Outgoing Quality Limit (AOQL) is the maximum value of the AOQ

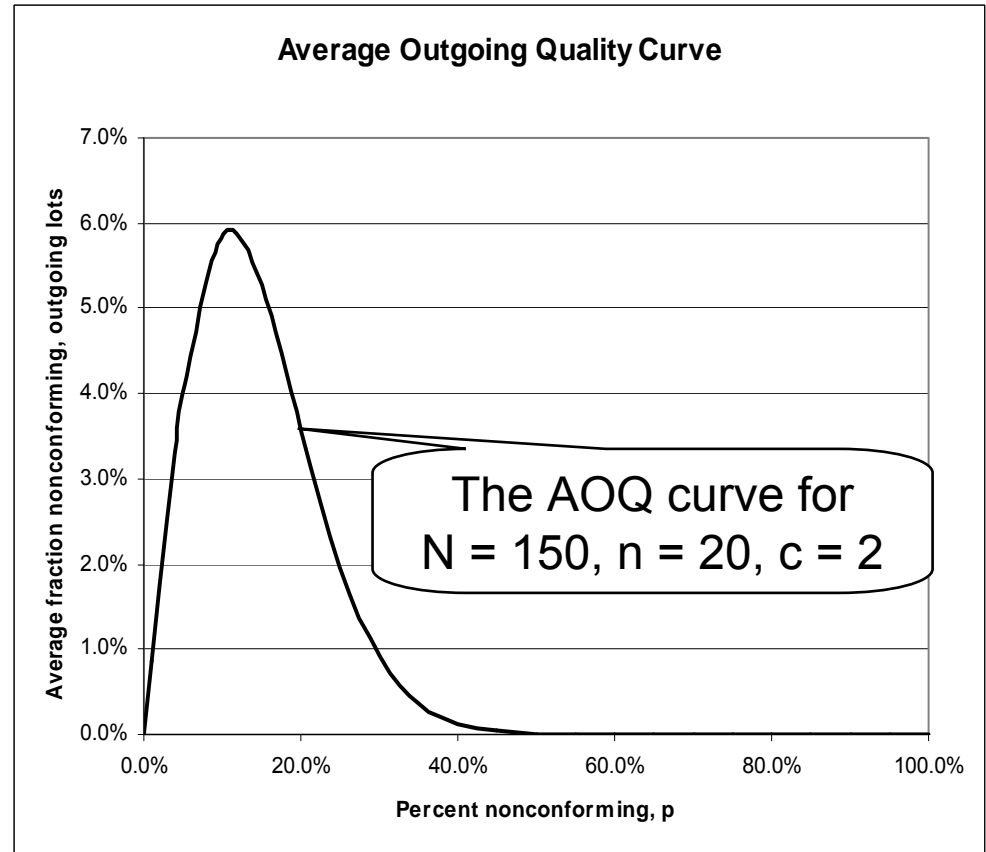

Average Total Inspected (ATI)

If the lot is fully conforming, $p=0.0$ ($P_a=1.0$), then we inspect only the sample

If the lot is totally nonconforming, $p=1.0$ ($P_a=0.0$), then we inspect the whole lot

$$ATI = n + (1 - P_a)(N - n)$$

For any given lot, we inspect either the sample or the whole lot. On average, we inspect only a portion of the submitted lots

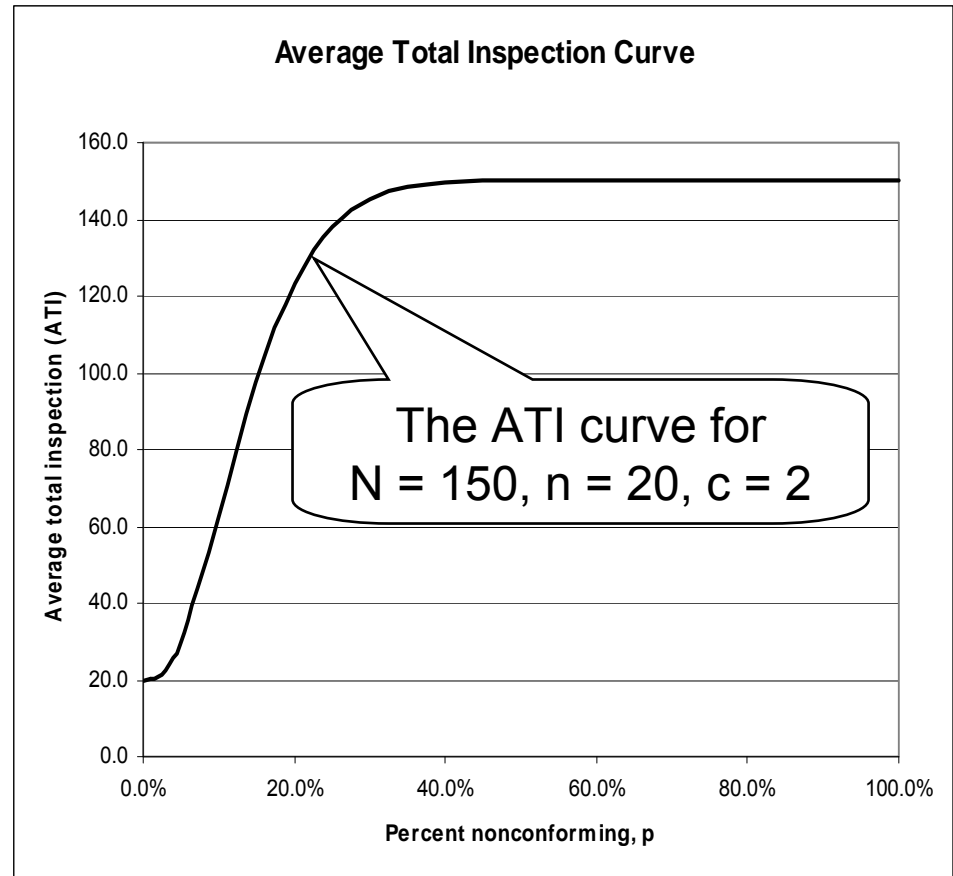

Average Sample Number (ASN)

For single samples, we always inspect the sample.

For double samples, we always inspect the first sample, but sometimes we can make a decision without taking the second sample.

Similarly for multiple samples, we don't always need to take the subsequent samples.

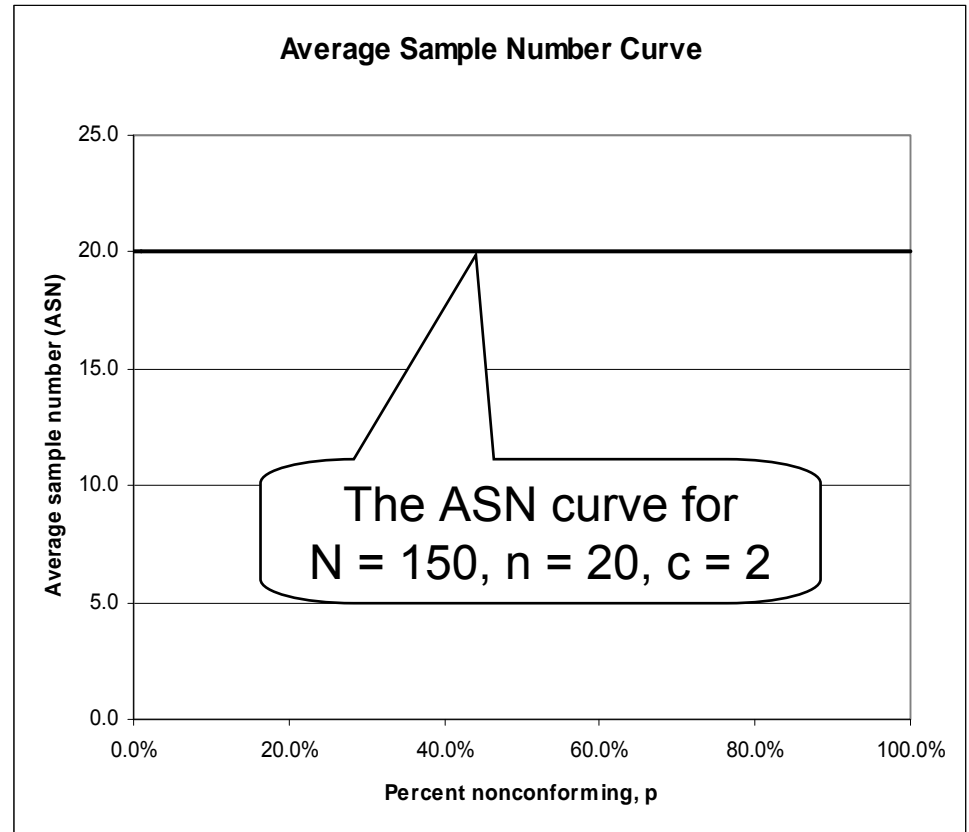

Attribute Sampling Plans

Z1.4 Double Sample Plans

Z1.4 Multiple Sampling Plans

Z1.4 Double Sampling

- Double sampling can reduce the sample size, and thereby reduce cost. (Each double sample is about 62.5% of the single sample.)
- Consider our case: $N = 150$, $AQL = 4.0\%$
- Table I gives Code letter F
- Table III-A gives the following plan
$$n_1 = 13, c_1 = 0, r_1 = 3$$
$$n_2 = 13, c_2 = 3, r_2 = 4$$
- On the first sample, we have three possible outcomes: accept, reject, or take the second sample
- On the second sample, we have only two choices, accept or reject.

Exercises

- Try Exercise #2
- Discussion Points
 - For the first sample, you had 2 nonconforming items from the sample, so you take the second sample.
 - When you take the second sample, what do you do with the first sample?
 - Assume you find 1 nonconforming item in the second sample, what is your decision on the lot?

Switching rules

- The same system of switching rules apply for double and multiple sampling.
- Running a multiple sampling plan system with switching rules can get very confusing.
- The administrative cost goes up along with the potential for error.

Z1.4 Recommendations

- Our recommendation for Z1.4
 - Implement double sampling instead of single sampling.
 - Use the switching rules to get to reduced inspection, again lowering sample sizes.
- Later, we will look at the $c=0$ plans

Characterizing double sampling plans

- OC Curve

$$P_a = P(x_1 \leq c_1) + \sum_{i=c_1+1}^{r_1-1} P(x_1 = i)P(x_2 \leq c_2 - i)$$

- ASN Curve

$$ASN = n_1 + n_2(1 - P_1)$$

- AOQ Curve

$$AOQ = \frac{p \times (P_a^1 \times (N - n_1) + P_a^2 \times (N - n_1 - n_2))}{N}$$

- ATI Curve

$$ATI = P_a^1 \times n_1 + P_a^2 \times (n_1 + n_2) + (1 - P_a) \times N$$

P_1 is the probability of making a decision (accept or reject) on the first sample

P_a^i is the probability of acceptance on the i^{th} sample

Attribute Sampling Plans

The $c=0$ Plans

We look at Squegolia's c=0 plans

- They are described in *Zero Acceptance Number Sampling Plans*, 5th edition, by Nicholas Squegolia
- They are often called “the c=0 plans”
- The Z1.4 plans tend to look at the AQL
- The c=0 plans look at the LTPD
 - They have (about) the same (LTPD, β) point as the corresponding Z1.4 single normal plan
 - They set $\beta = 0.1$

Exercise #3

- Conduct Exercise #3
- Discussion points
 - Notice this is a single sampling plan. What if you used the sample size from Z1.4, but always set $c = 0$?
 - At the beginning of next month, you decide to switch from Z1.4 to $c = 0$. Your supplier's process average is 2%. (Use the large OC curves to estimate the answer.)
 - What percentage of lots are rejected using Z1.4?
 - What percentage of lots are rejected using $c=0$?

Recall our earlier discussion of specific points on the OC Curve

The Producer's Risk has a value of α .
The point $(p_1, 1-\alpha)$ shows the probability of accepting a lot with quality p_1 .

The Consumer's Risk has a value of β .
The point (p_2, β) shows the probability of accepting a lot with quality p_2 .

The point $(p_3, 0.5)$ shows the probability of acceptance is 0.5.

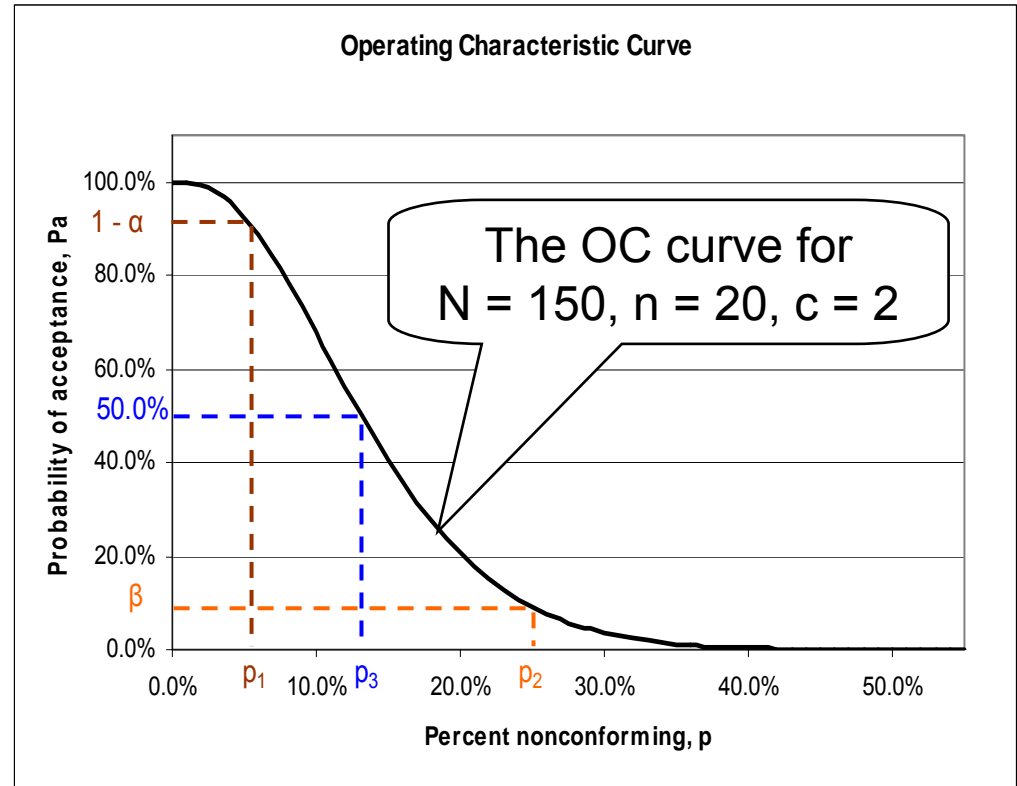

The difference between the plans

- The $c=0$ plans are indexed by AQLs to help make them comparable with the Z1.4 plans
- The calculations in the $c=0$ plan book use the hypergeometric distribution while Z1.4 uses the binomial (and Poisson).
- The $c=0$ plans try to match the Z1.4 plans at the RQL (or LTPD) point.

Comparison of plans

- An example

Z1.4:

N=1300,
AQL=4.0%,
n=125,
c=10

c=0:

N=1300
AQL=4.0%
n=18
c=0

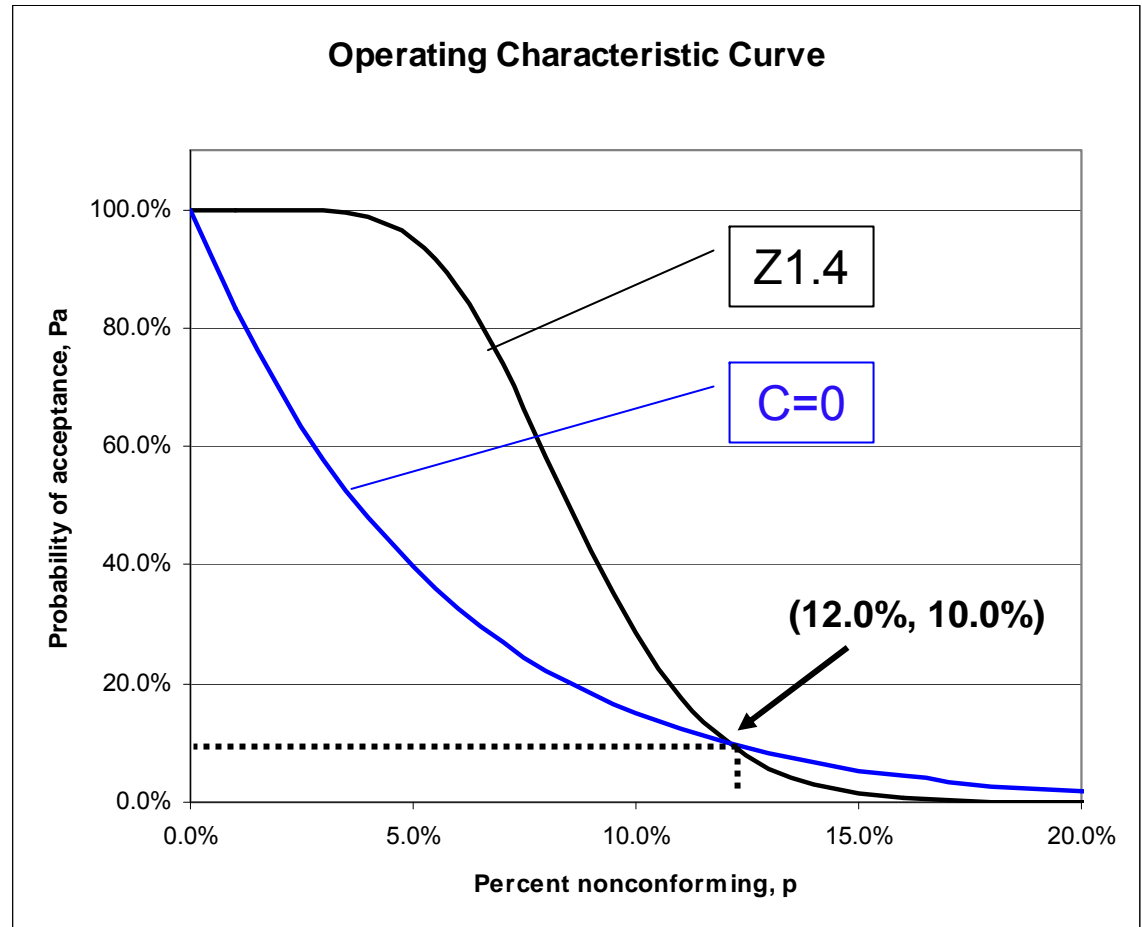

Some things to observe

- Between 0% nonconforming and the LTPD, the $c=0$ plan will reject more lots.
- Consider the preceding plan at $p = 2.0\%$
 - P_a for the Z1.4 plan is (nearly) 100%
 - P_a for the $c=0$ plan is 69.5%
- Hold everything else the same and change from Z1.4 to the corresponding $c=0$ plan
 - Your inspection costs drop from 125 to 18 pieces
 - Your percentage of rejected lots goes from nearly 0% to about 30%.

c=0 Switching rules

- The c=0 plans don't require switching, but offer it as an option.
 - For tightened go the next lower index (AQL) value
 - For reduced go to the next higher index (AQL) value
- Switching rules
 - N → T: 2 of 5 rejected
 - T → N: 5 of 5 accepted
 - N → R: 10 of 10 accepted
 - R → N: 1 rejected

Summary

Four Important Curves

- Operating Characteristic (OC)
 - The probability of acceptance as a function of the process nonconformance rate
- Average Sample Number (ASN)
 - The average number of items in the sample(s) as a function of the process nonconformance rate
 - For single sample plans, it is a constant
- Average Outgoing Quality (AOQ)
 - For rectifying inspection, the quality of the outgoing material
 - The worst case is the Average Outgoing Quality Limit (AOQL)
- Average Total Inspected (ATI)
 - For rectifying inspection, the total number of items inspected a function of the process nonconformance rate

ANSI/ASQ Z1.4

- Offers a huge variety of sampling plans
 - The standard has single, double, and multiple sampling plans
 - The standard includes dynamic adjustments based on the process history (switching rules)
 - The standard offers seven levels for discrimination
- Uses the binomial (or Poisson) distribution

C=0 plans (Squeglia)

- Addresses a common criticism of Z1.4
 - One can accept a lot with nonconforming material in the sample.
- All plans have $c=0$
 - All OC curves are the special case when $c=0$
 - The sample sizes tend to be (much) smaller than the corresponding Z1.4 plans
 - Based on the hypergeometric distribution and matched to the Z1.4 plan at the RQL point
 - Indexed by the Z1.4 AQL values for compatibility